

Installation Instructions

85100 Window Protector

This Window Protector is designed to fit the following truck models:

- FORD F-150** all models 1997-Present
- FORD F250/350 Super Duty** Regular Cab 1997-1999
- CHEVY/ GMC 1500/2500** Regular Cab, Extended Cab and Crew Cab 1999-Present
- DODGE Ram 1500** Regular Cab 1997-2001
- DODGE Ram 1500** Quad Cab 1997-2000
- DODGE Ram 1500** Quad Cab 2001 (155" wheel base only)
- DODGE Ram 2500** Regular Cab 1997-2001

IMPORTANT: Check Owner's Manual or contact your truck manufacturer for all necessary Pickup Box Reinforcement Kits. Always install recommended kits prior to Window Protector installation. Failure to follow this procedure may void truck's warranty. Never exceed recommended maximum combined weight of equipment and cargo, recommended by truck's manufacturer.

Installation Instructions, Warranty Information.
 Place in vehicle glove box after installation.

CAUTION

- Park your vehicle on flat, horizontal surface. Apply parking brake or use wheel chocks to prevent accidental rolling.
- To keep debris out of your eyes always wear protective eyewear.
- Tighten screws and nuts only when it is recommended by these instructions.
- Check contents of box against part list to make sure all components are included

Tools Required

- 3/4" Open or Socket Wrench (2)
- Electric Drill
- 3/4" Drill Bit

1. Determine which hole on the bracket to be used. Mark the appropriate hole for your vehicle on both brackets.
 See Fig. 1

2. Apply adhesive cushions to brackets. Punch holes in cushions according to marked holes in brackets.
 See Fig. 2

3. Attach anchors to brackets using 1/2-13 x 1-1/2" screws. Use 1/2-13 x 4" for Ford F-150 2004 new style. Do not tighten screws. Make only 3-5 turns into anchor's short side nut.
 See Fig. 3

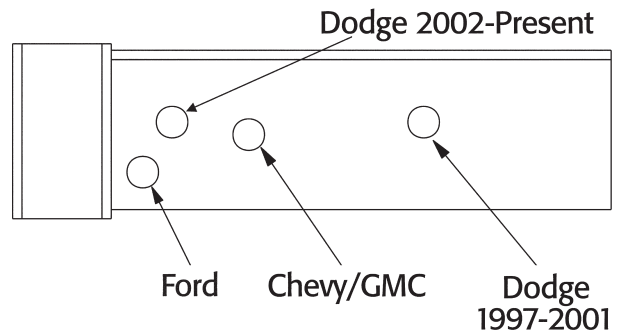
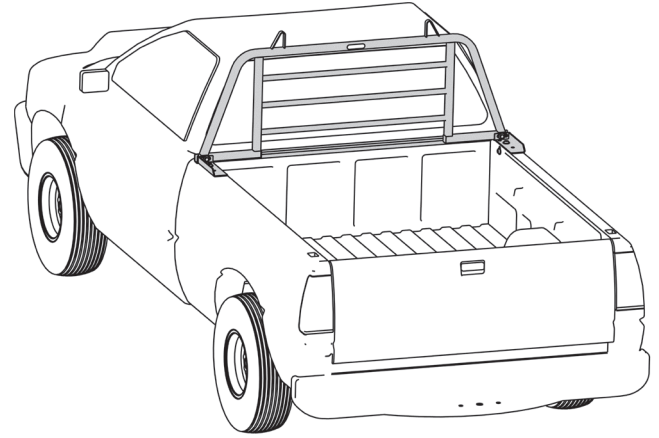

Fig. 1 Bracket, Top View

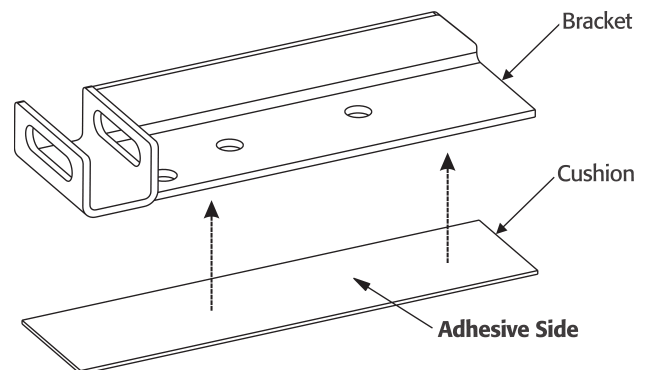

Fig. 2

4. If side rail covers are installed, remove protective caps from the front stake pockets or cut openings in the rail covers to expose the front stake pockets.

If present, drill holes in bedliner walls to open access to front stake pocket side holes. Many models of bedliners have a small mark on a wall against front stake pocket. Use it to drill necessary holes.

Insert anchors into stake pockets. Make sure that the anchors' long sides are facing inside the bed.

Align holes in anchors with stake pocket openings and install hardware loosely from inside of the bed.

See Fig. 4

5. Position the Window Protector on the front wall of the truck box with the "Buyers" decal facing rearward. Slide the sides of Window Protector in the "U" shaped guides of the brackets. Align the brackets' slots with holes in the Window Protector and insert 1/2-20 x 2-1/2" screws. Install lock nuts.

See Fig. 5

Position the Window Protector symmetrically on the vehicle. Tighten lock nuts evenly on both sides with torque 60-70 foot-pounds. Tighten screws on brackets until the lock washers are flattened plus 1 - 1-1/2 turns. Overtightening these screws can result in damage to truck's sheet metal.

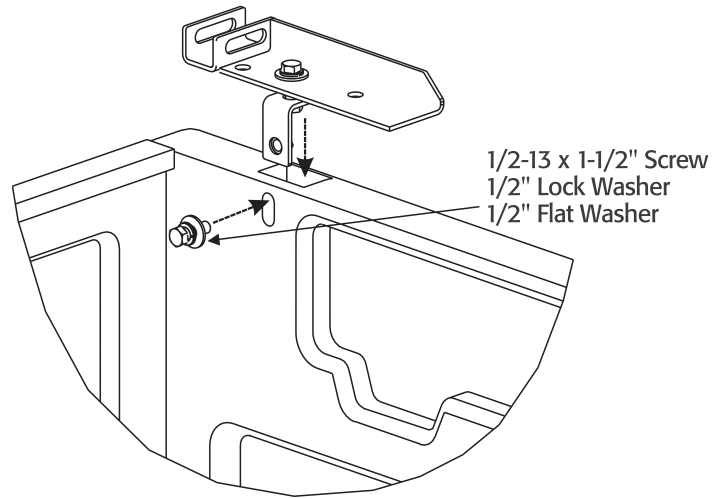
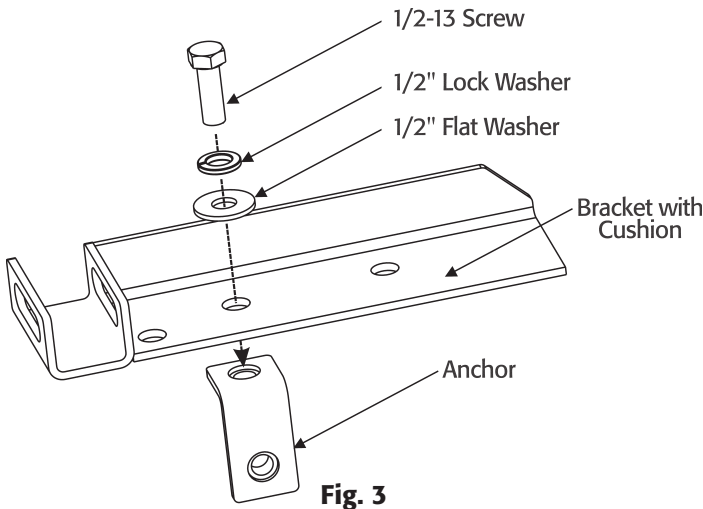

Fig. 4

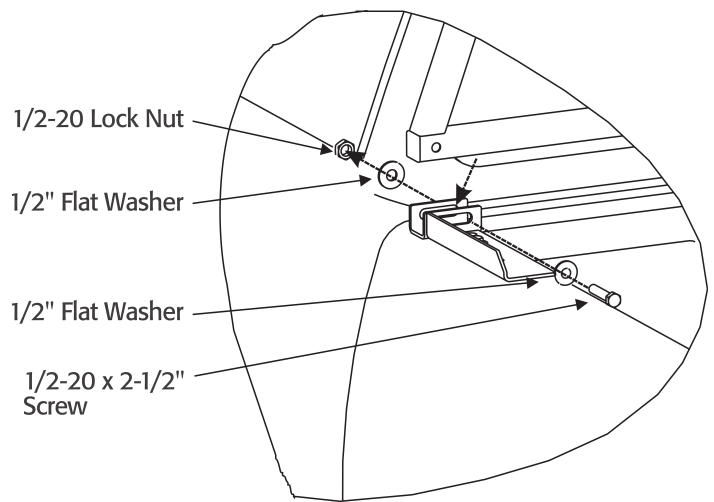

Fig. 5

Bill of Materials

PART NO.	QTY.	DESCRIPTION
3003263	1	Protector, Rear Window (full size truck)
3002748	1	Bracket, left hand side
3002822	1	Bracket, right hand side
3003598	1	Instruction Sheet
-	8	Washer, flat 1/2"
-	2	Screw, hex head 1/2-20 x 2-1/2"
-	4	Washer, lock 1/2" split
-	2	Nut, center lock 1/2-20
3003250	2	Cushion, self-adhesive
3002723	2	Anchor
-	4	Screw, hex head 1/2-13 x 1-1/2"
-	2	Screw, hex head 1/2-13 x 4"

Full One-Year Warranty

Manufacturer will repair, or at manufacturer's discretion will replace any part of this Window Protector which proves to be defective in workmanship or material under normal use for period of one year from the date of delivery to the original purchaser. Any cost incurred in returning the product to the supplier is the responsibility of the consumer.

Exclusions

Manufacturer shall not to be liable for special, incidental, or consequential damages or for damages resulting from lack of necessary maintenance, from misuse, abuse, act of God, or alteration of the product. Some states do not allow the exclusion or limitation of incidental or consequential damages, so the above limitation or exclusion may not apply to you.