

Installation Instructions

AS301 Air Shift Cylinder

The AS301 Air Shift Cylinder mounts to Buyers BPC1010-Series, Permco 640-Series, or Commercial C101-Series Dump Pump/Valve in place of the detent assembly.

Disassembly



1. Using snap ring pliers, remove snap ring from valve spool.



2. Remove retaining ring from valve spool.



3. Remove detent cap, spring and ball from valve's end cap.

Assembly



4. Remove four cap screws and slide end cap off spool. **Do not remove O-ring from valve housing.** Clean mounting face of valve housing and spool.



5. Place large O-ring and spring retainer over valve spool with smaller diameter hole in retainer toward valve casting. Be sure O-ring in valve housing is properly seated.



6. Apply light coating of grease to small O-ring and carefully place it into large detent groove in valve spool.

If end cap has a wiper seal, clean spool. Wrap a layer of thin, clear tape over groove to prevent seal from catching in it when you remove cap. Remove tape before installing Air Shift Kit.

—Installation Instructions continued on back

Assembly, cont. from front



7. Hold opposite end of spool and push on piston assembly until piston hole lines up with hole in valve spool. Slide clevis pin into hole.



8. Apply a light coating of grease to quad seal ring. Slip snap ring onto clevis pin to secure it.



9. Slide pressure cap over assembly and push tight against valve body. Tighten cap screws finger tight. Shift spool back and forth to assure centering of air shift.



10. Alternating cross corners, torque cap screws to 24 ft. lbs.



11. Install air lines from valve in cab to air cylinder.

Air in port A shifts spool to raise position.

Air in port B shifts spool to lower position.

Minimum air supply 80 psi.

An air dryer or water filter is recommended in air supply for cold weather operation.

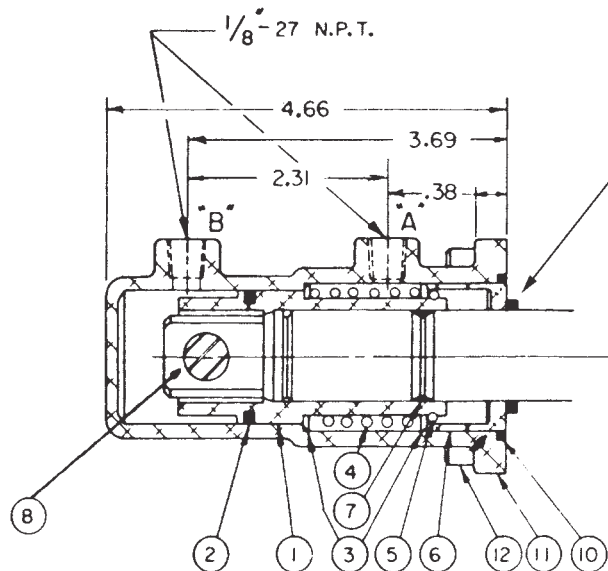

Be sure O-ring is in proper position in groove in valve housing before starting assembly.

Item	Description	Req'd.
1	Piston	Piston Sub-Assembly
2	Quad Seal Ring	
3	Spring Retainer	
4	Spring	
5	Wire Ring	
6	Spring Retainer	1
7	O-Ring	1
8	Clevis Pin	1
9	Snap Ring	1
10	O-Ring	1
11	Pressure Cap	1
12	Cap Screw	4

